

DALLAS VINYL

SY01

&

Model No. VD1012-D1

697.68619-A1

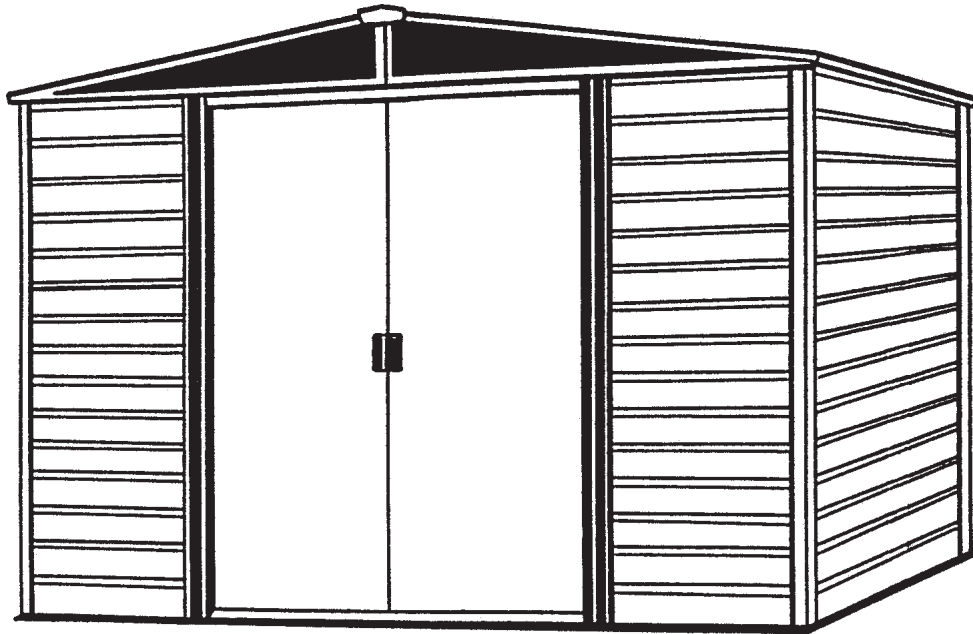

714541207



- / () ()

3,0m x 3,6m 307cm x 364cm 10,7m² 20,8m³ 313cm 370cm 209cm 300cm 357cm 205cm 141cm 176cm

■ ■ ■

Frame Kit Arrow Anchoring Kit

: Arrow Floor

12.

: 8 (495) 966-23-86

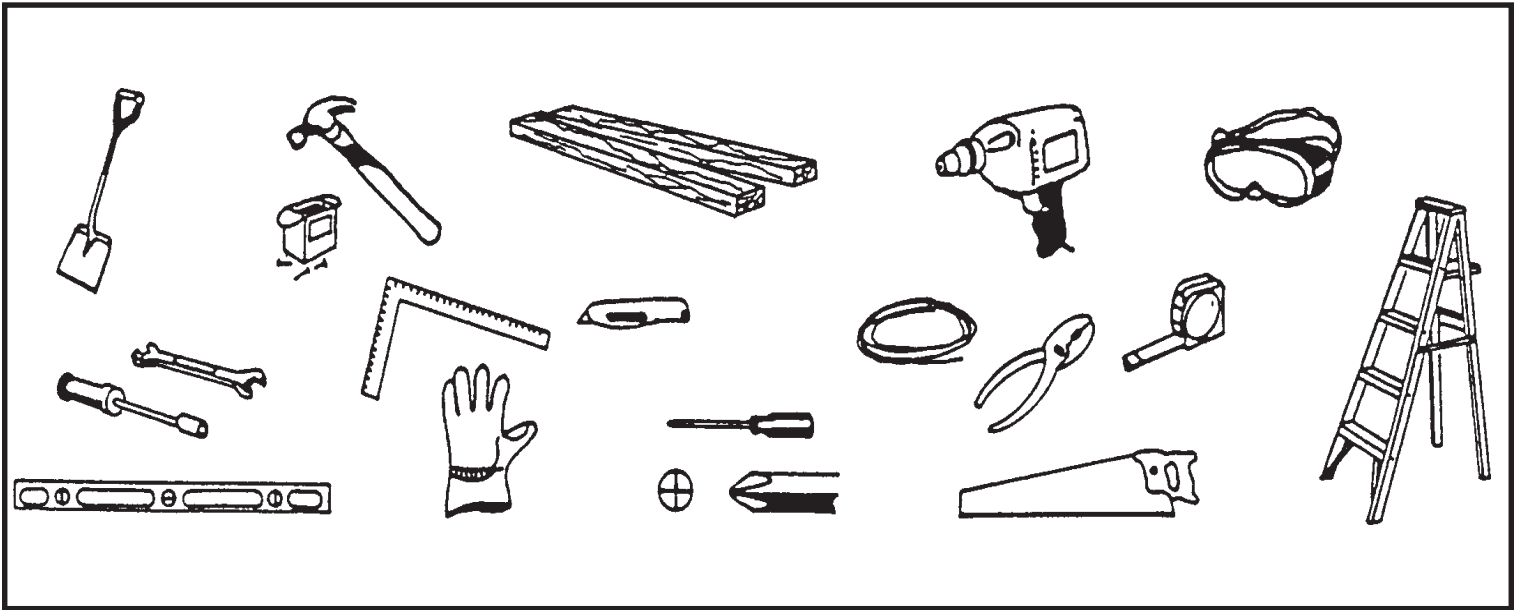

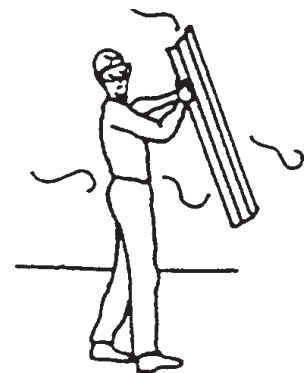
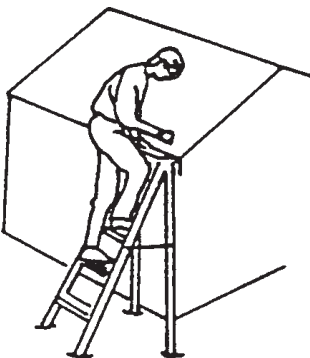
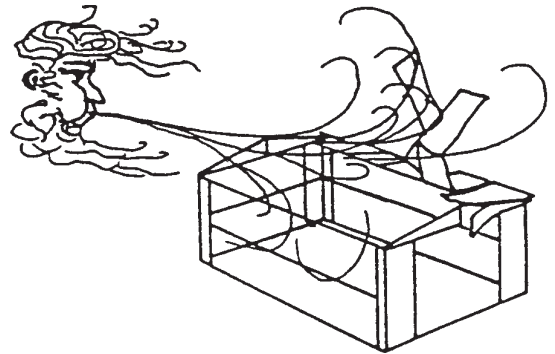
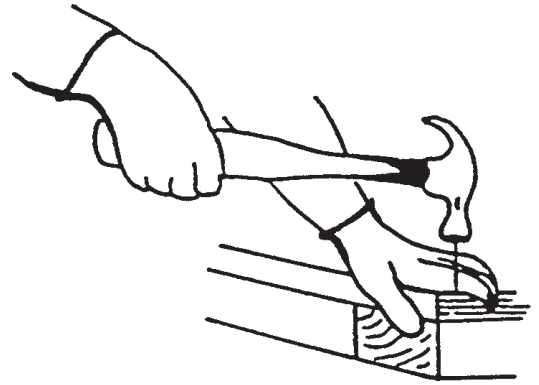
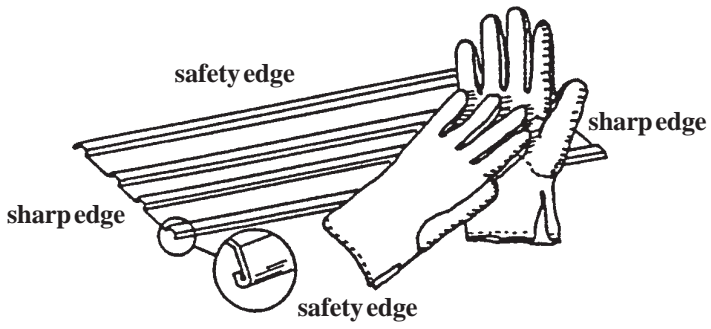

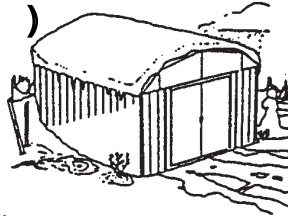

50%.

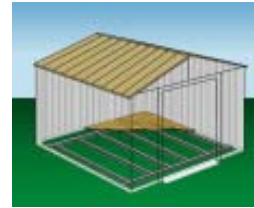

FB47410, FB5465, FB106-A
FB109-A FB1014-A

4

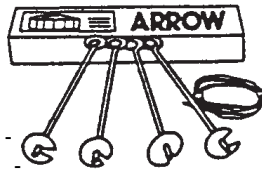

, 18

4

3,0 x 2,6

2

100

101

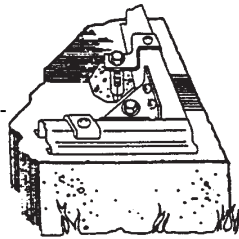

3,0



113

1/4

600

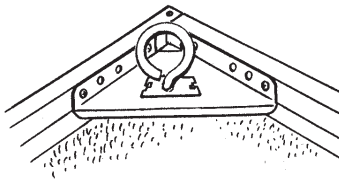

4

100

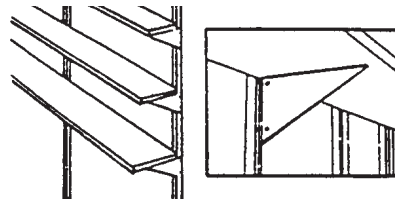

SS404

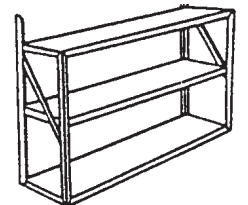

SS900-

(64,8)

20,3 30,5

• 3
•

38





AQ9



1:

ARROW (

No. FB106-A or 68381-A)

ARROW

- 1)
- 2)

ARROW
ARROW

2-

ARROW

2:

- 50 x 100
 - 15,5 1220 x 2440
 - ()

6-7

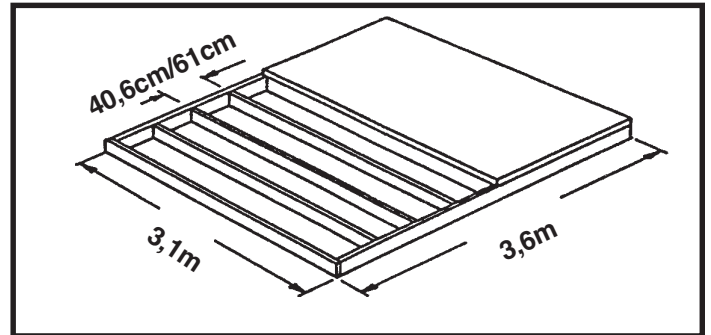

3:

10,2

- 1. 15 ()
- 2. 10
- 3. 6
- 4. (10 2,5)
- 5. 10

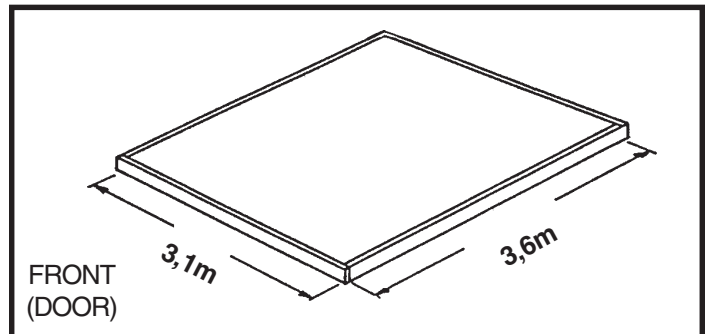



ARROW: (AK4 60298)

: 4

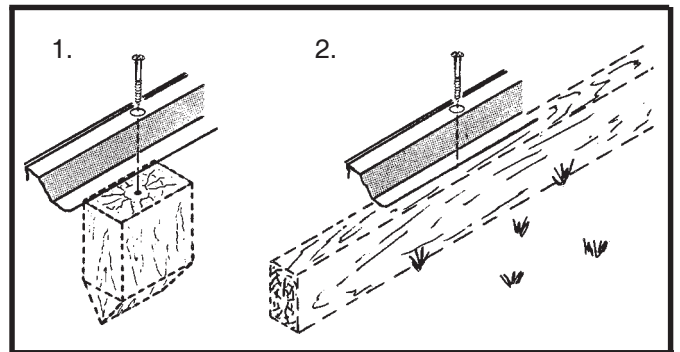
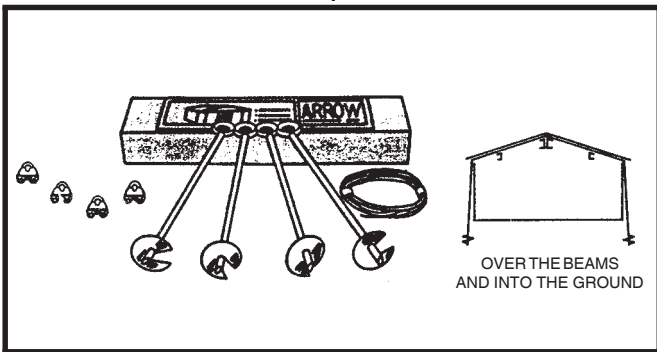

ARROW: (AK100 68383)

ARROW.

6

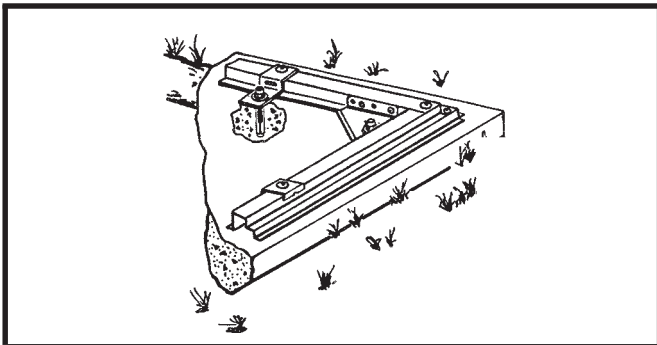

1. (6 x 51).

2. 6 x 152

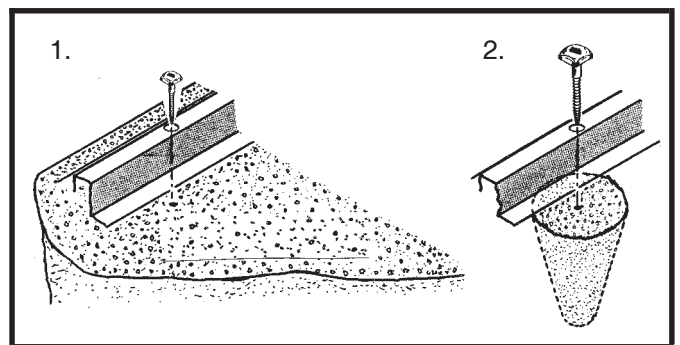



65103
#8-32 Hex Nut (149)



65900A
#10Bx1/2" Black Screw (8)
(Packed with Screws)



65923
#8-32x3/8" Bolt (135)



65004
#8Ax5/16" Screw (404)

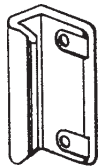

66045
Handle (2)

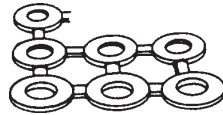

66646
Washer (280)
(8 sheets of 40)



65109
#8-32 Acorn Nut (14)
(Packed with Screws)

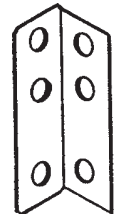

5971
Roof Beam Bracket (4)



66769
Door Slide (4)

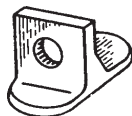

66382
Lower Door Guide (4)

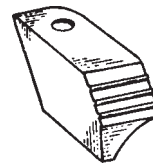

66183
Roof Trim Cap
(2 right & 2 left)



67468
Peak Cap (2)
(Arrow Logo)

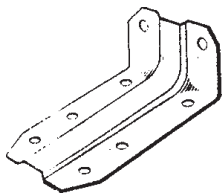

6228
Track Support (2)

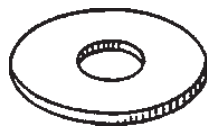

65020
Door Washer (14)
(Packed with Screws)

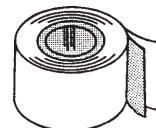

67545
Weather Stripping (1)



65958
#8-32x7/8" Bolt (14)
(Packed with Screws)

			-	
1	9365	Front Wall Channel	2	
2	5287	Splice Post	3	
3	5288	Corner Post	4	
4	6000	Right Gable	2	
5	6001	Left Gable	2	
6	6287	Side Siding	12	
7	6529	Roof Panel	6	
8	6640	Right Roof Panel	2	
9	6641	Left Roof Panel	2	
10	7311	Door Jamb	2	
11	10501	Horizontal Door Brace	4	
12	8641	Vertical Door Brace	2	
13	8736	Rear Siding	6	
14	8737	Front Siding	6	
15	10493	Right Door	1	
16	10493	Left Door	1	
17	67731	Foam Board	2	
18	6403	Door Track Splice	1	
19	6014	Side Roof Trim	2	
20	6015	Side Roof Trim	4	
21	6868	Ridge Cap	1	
22	6869	Ridge Cap	2	
23	9366	Door Track	2	
24	10396	Rear Wall Angle	2	
25	6635	Gable Brace	2	
26	10397	Roof Beam	8	
27	10392	Side Floor Frame	4	
28	8936	Rear Floor Frame	2	
29	9367	Front Floor Frame	2	
30	9344	Siding Stud	10	
31	10395	Side Wall Angle	4	
32	8934	Ramp	1	

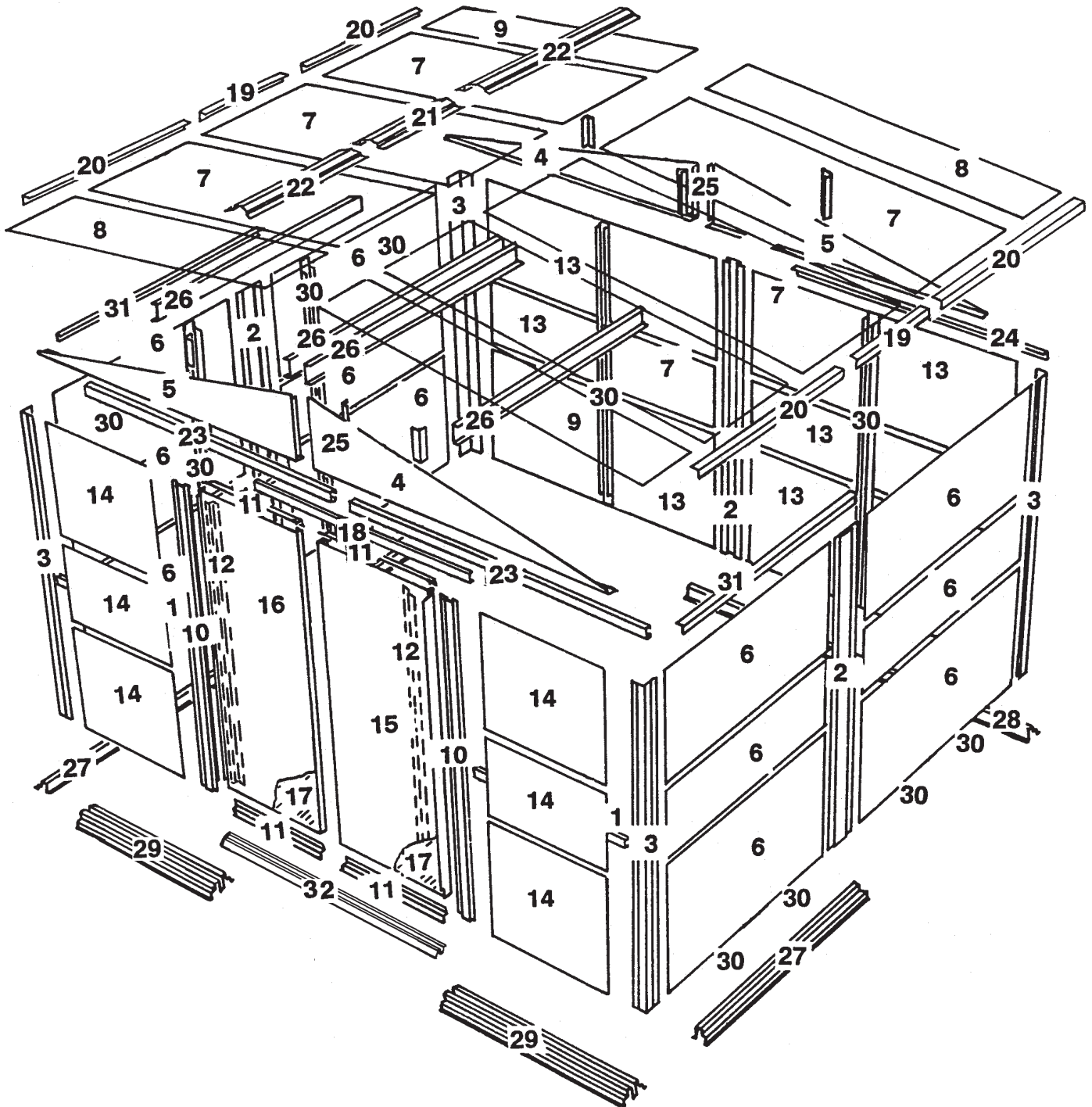

1

- 8934 Ramp (1)
- 9367 Front Floor Frame (2)
- 8936 Rear Floor Frame (2)
- 10392 Side Floor Frame (4)

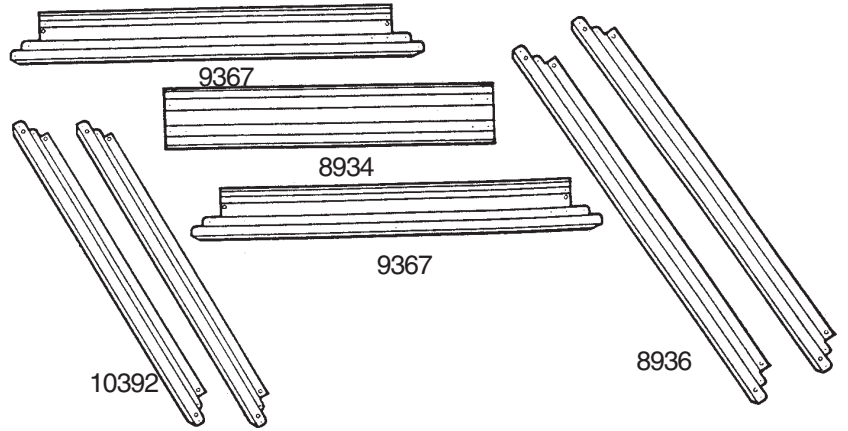

1

STEP 1

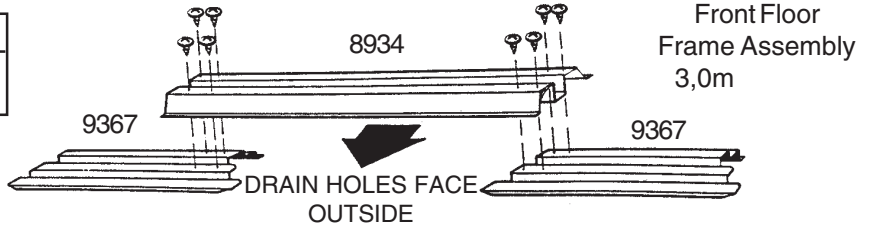

8-

2

STEP 2

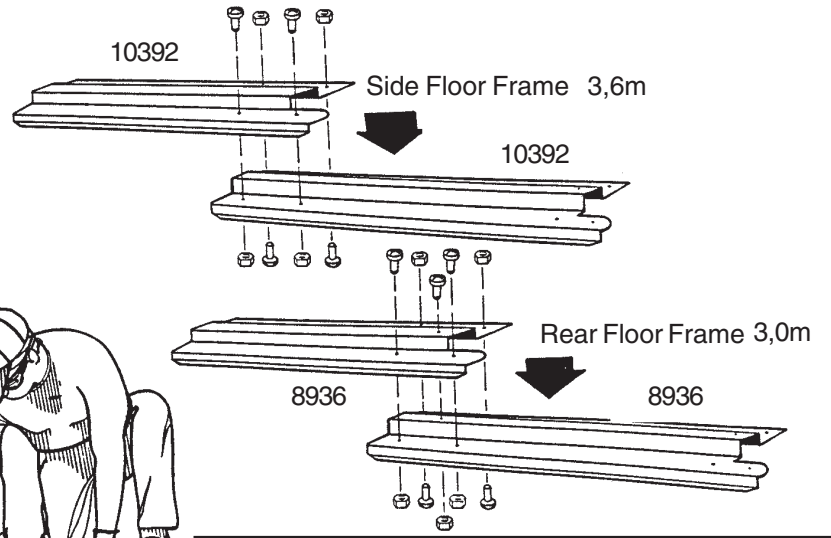

4/5-

3

STEP 3

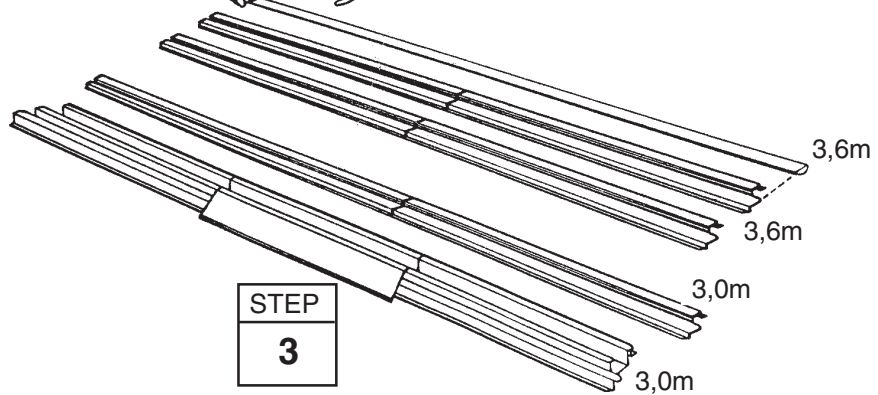

2

- 10396 Rear Wall Angle (2)
- 10395 Side Wall Angle (4)

1

2

3

STEP
1

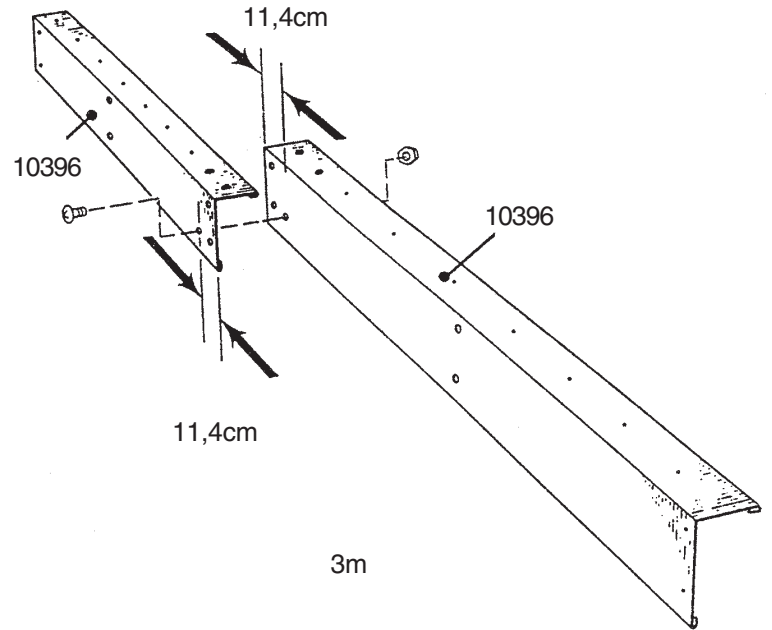

STEP
2

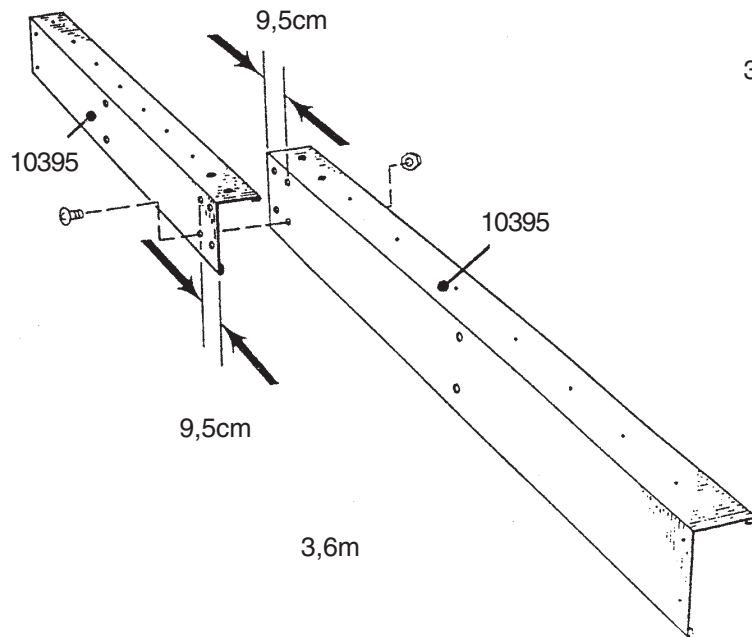

1

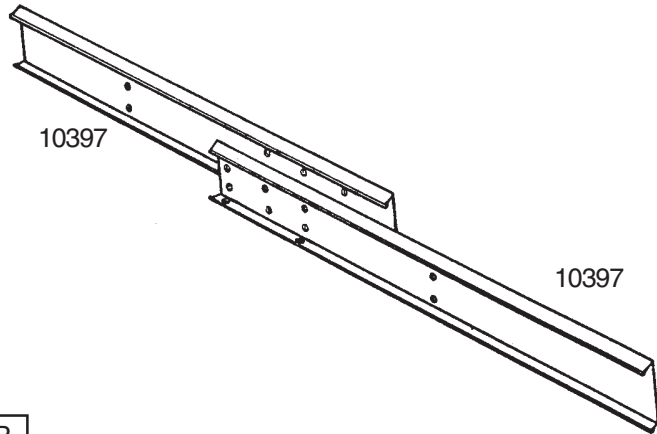

4

!!!

STEP
1

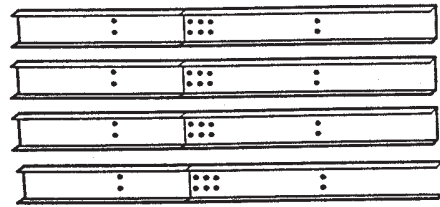

2

14-

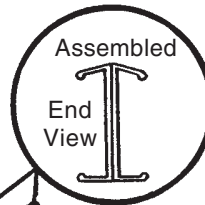

STEP
2

3

STEP
3

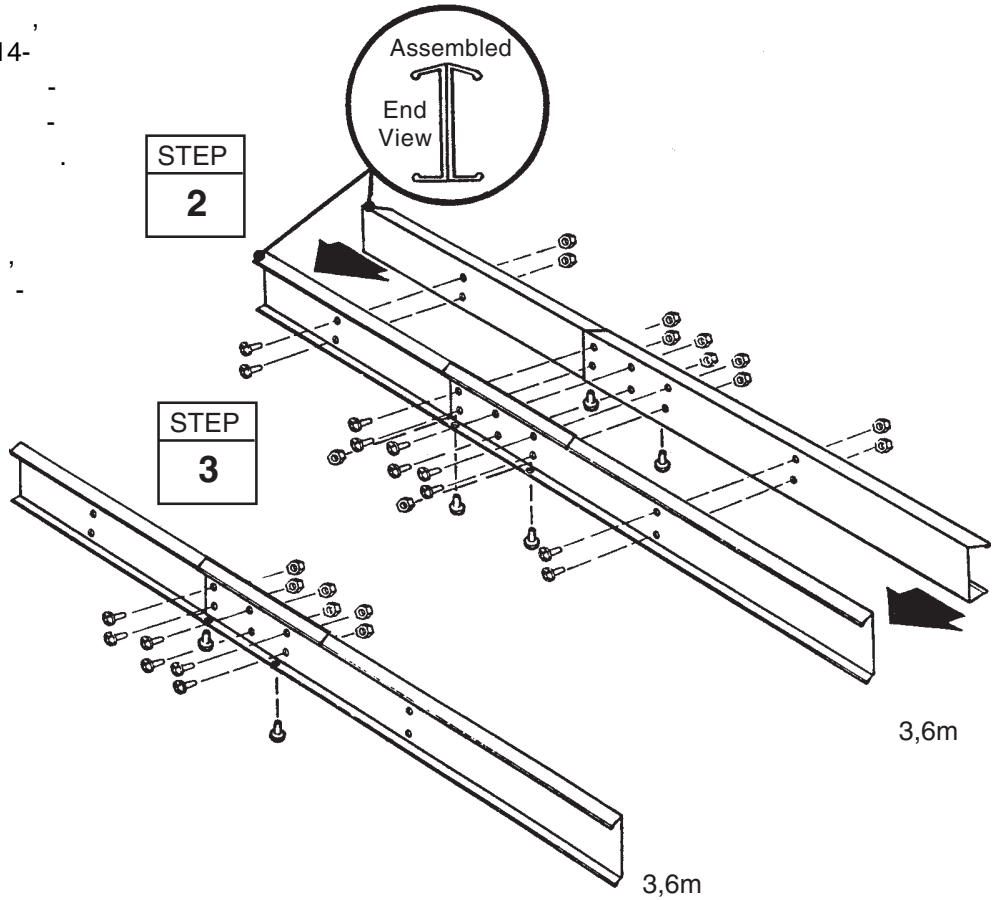

4

4

- 6403 Door Track Splice (1)
- 9366 Door Track (2)

NOTE:
Door Track Splice (painted part)

1

()

2

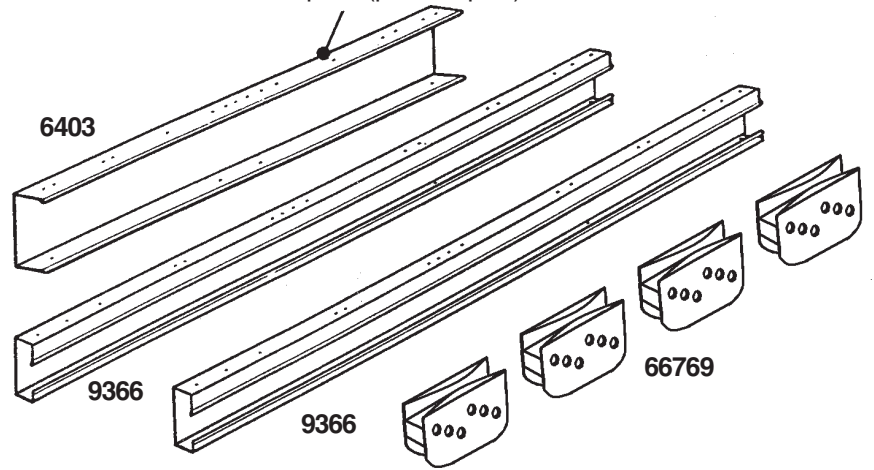

STEP
1

STEP
2

3

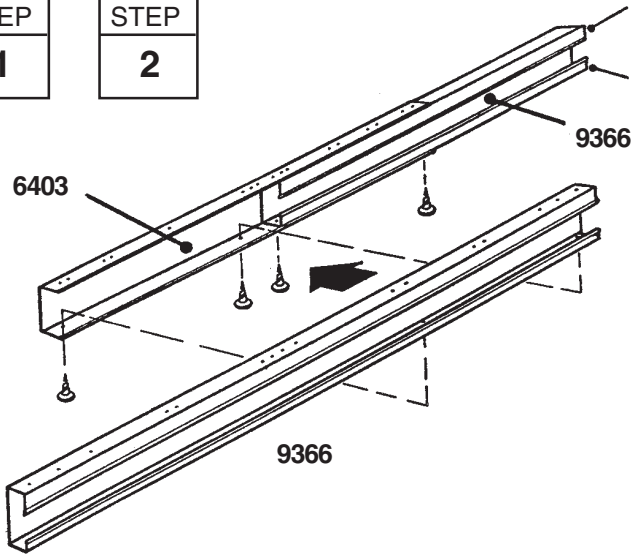

4

STEP
3

STEP
4

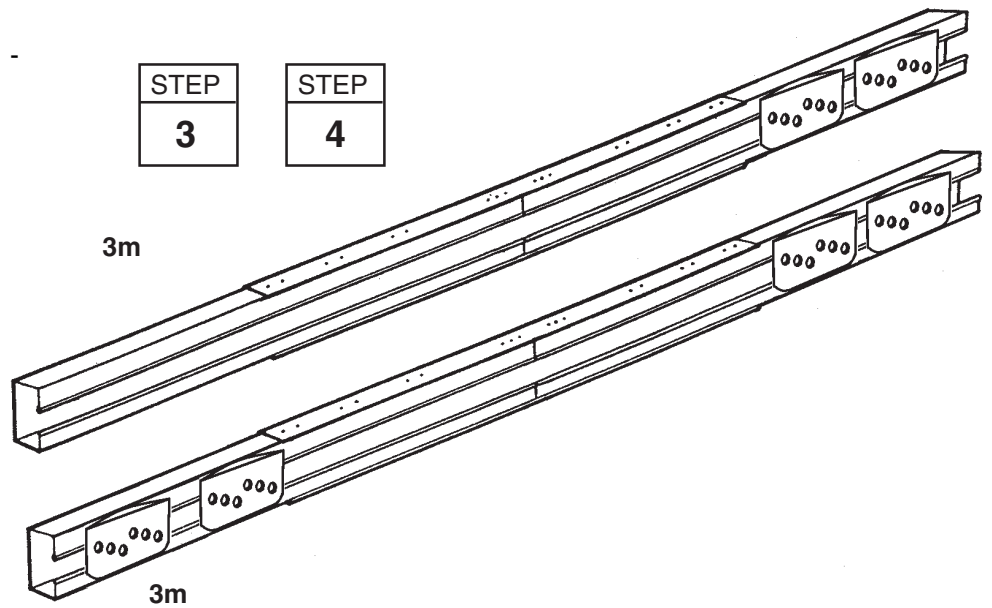

END VIEW

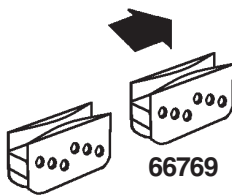

5

- Front Floor Assembly (1)
- Side Floor Assembly (2)
- Rear Floor Assembly (1)

1

STEP
1

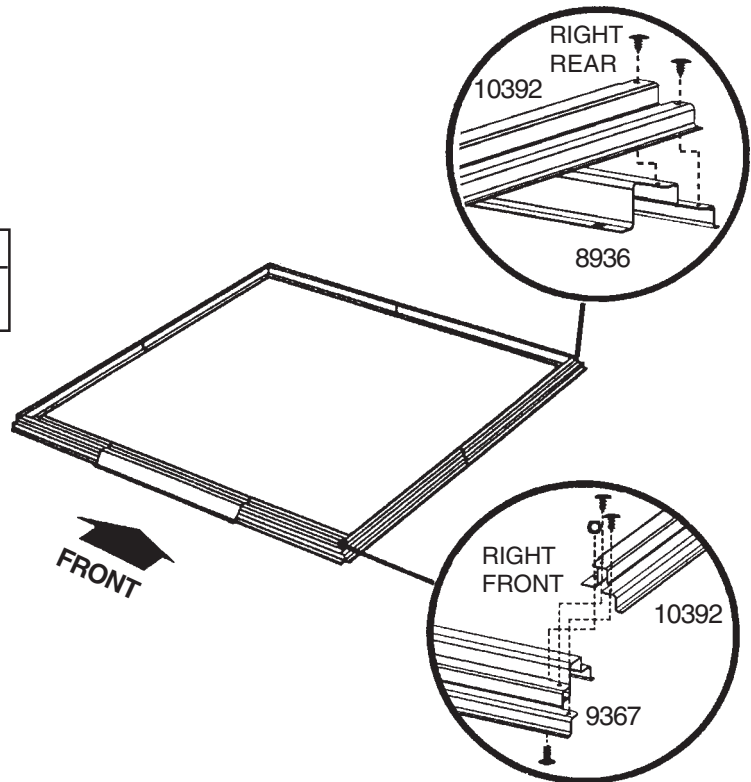

2

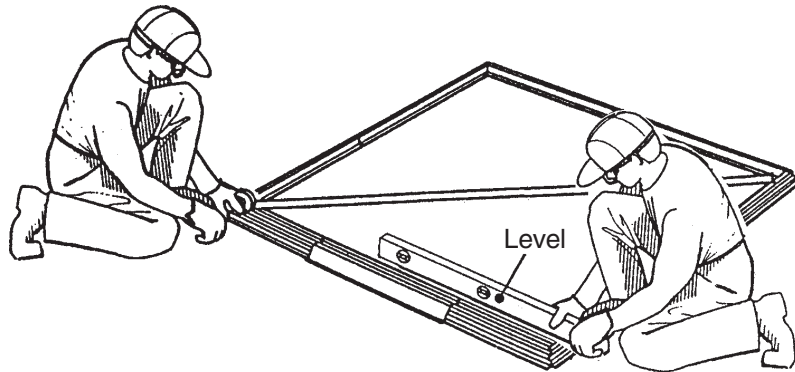
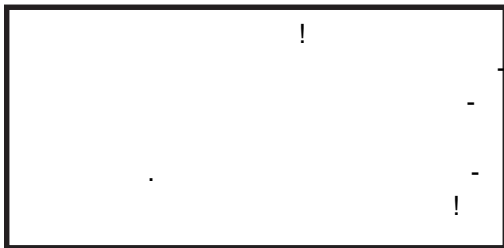

STEP
2

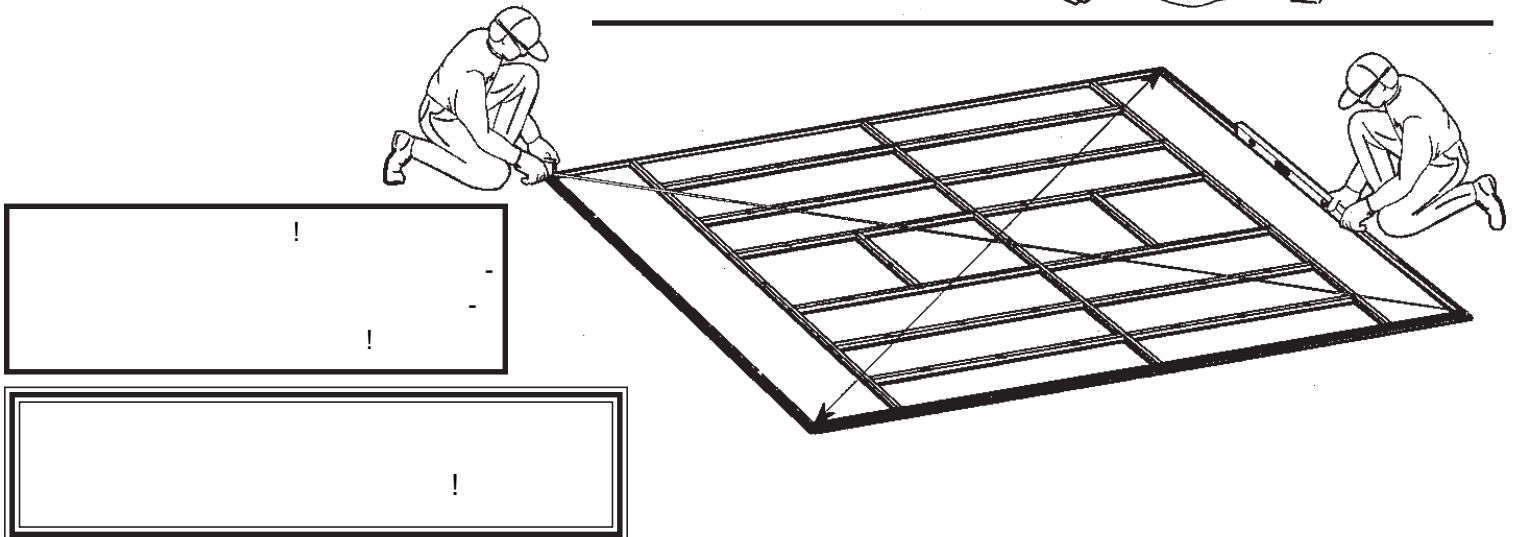

SX19



1

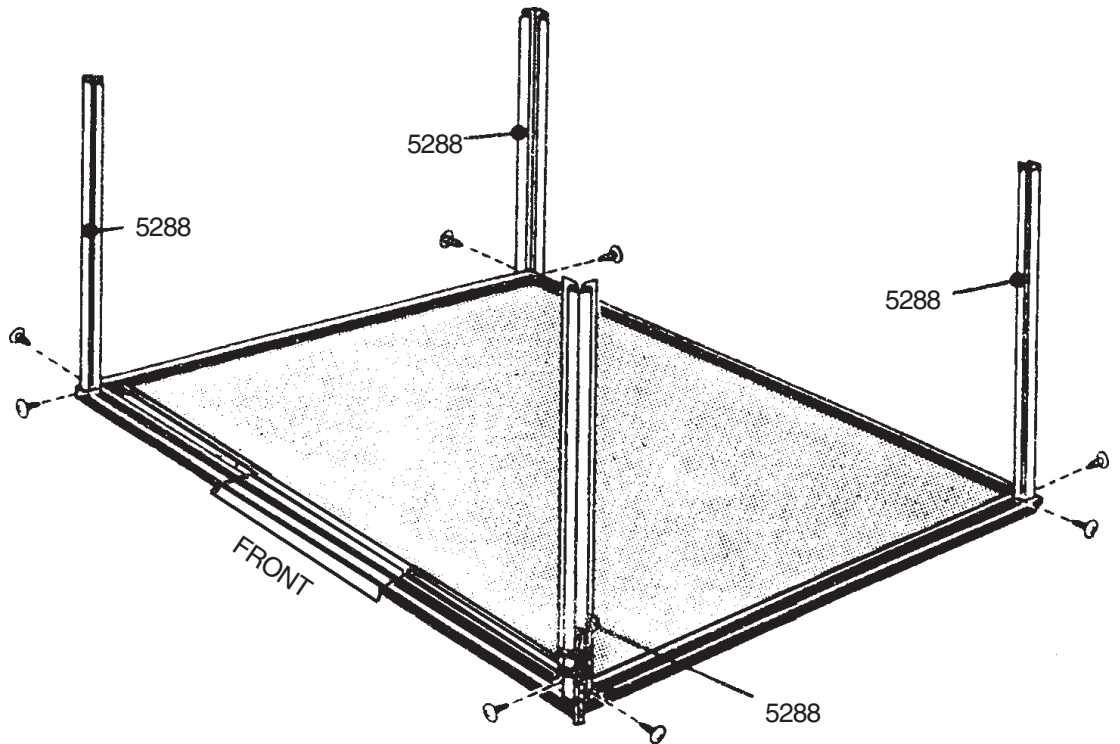
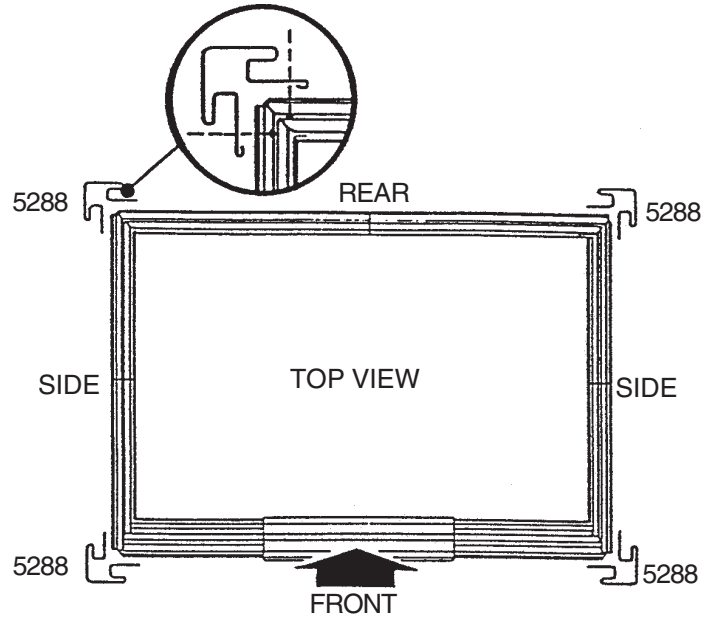

7

- Door Track Assembly (1)
- Rear Wall Angle Assembly (1)
- Side Wall Angle Assemblies (2)

1

2

3

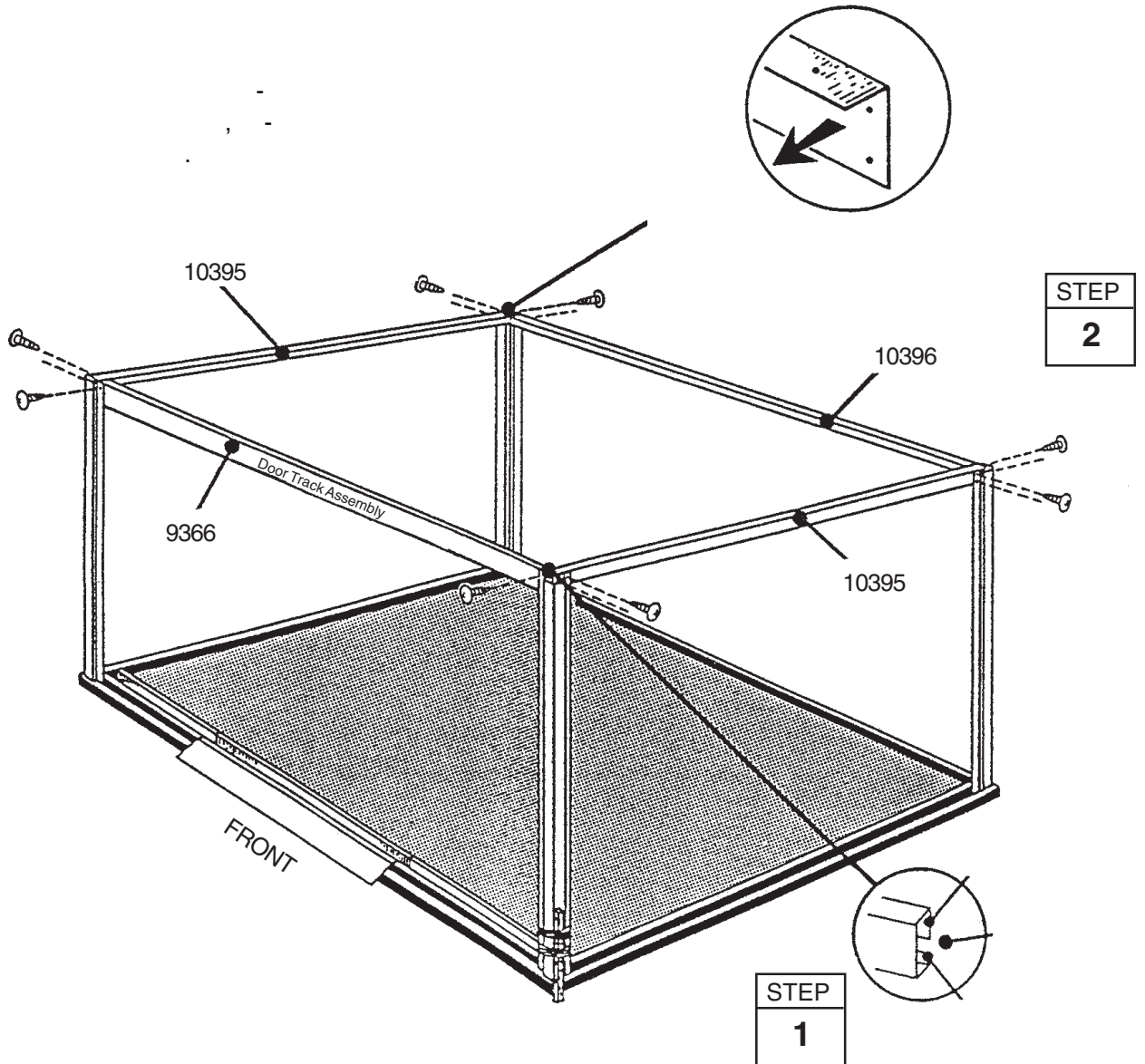

8

● 5287 Splice Post (3)

1

4-

2

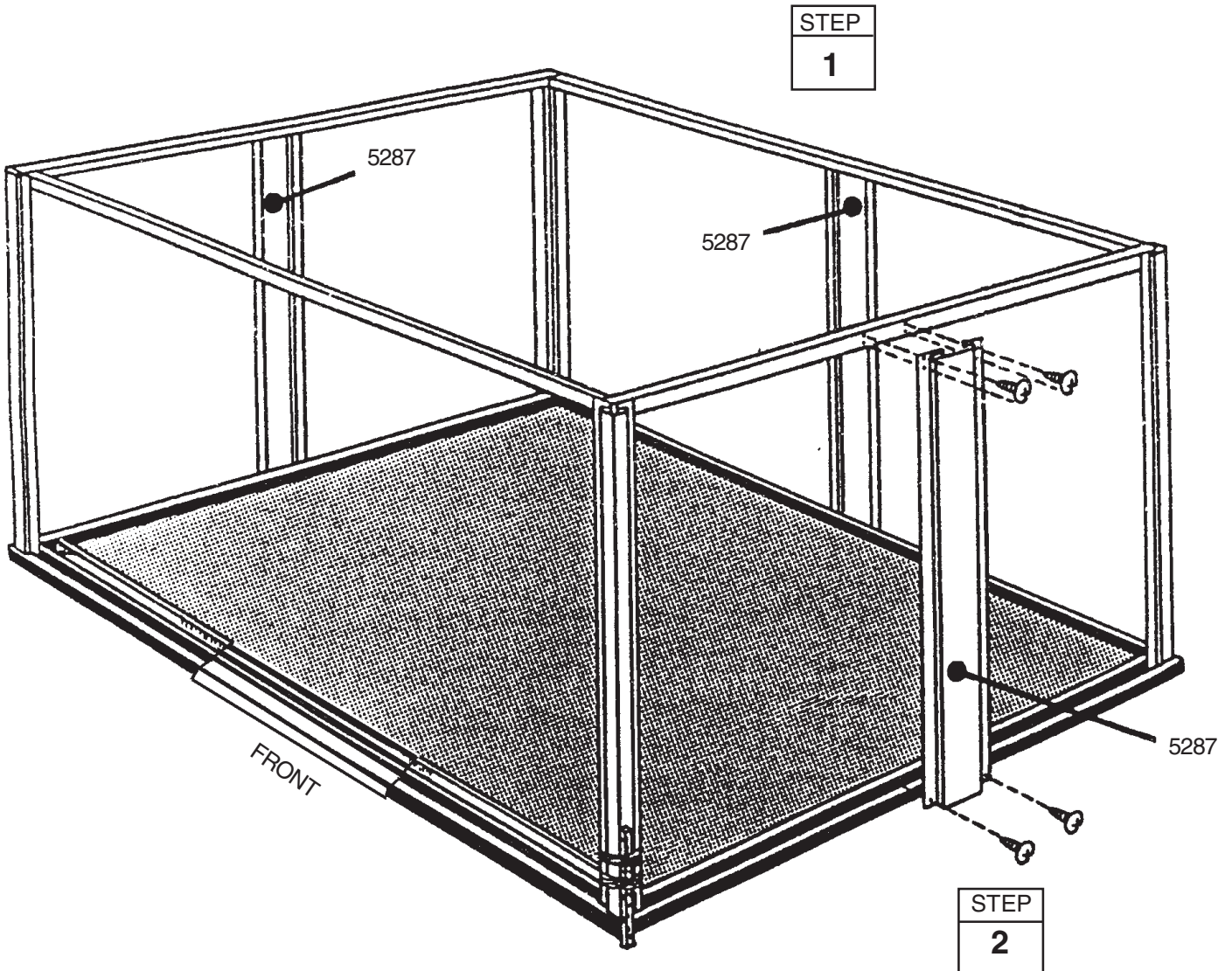

1

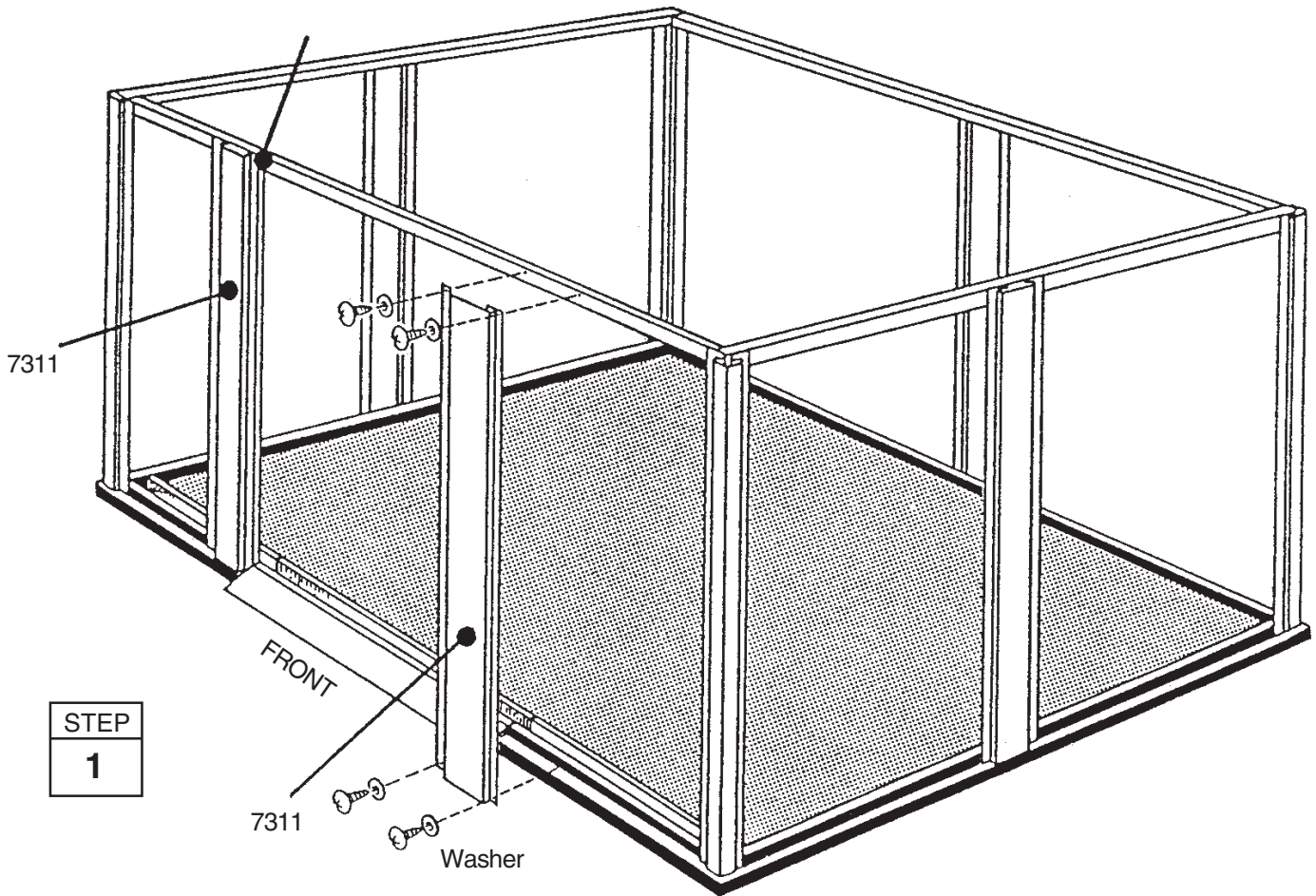

10

- 9344 Siding Stud (10)
- 9365 Front Wall Channel (2)

SX23

1

2

3

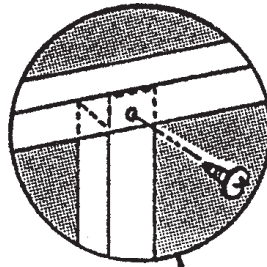

STEP
1

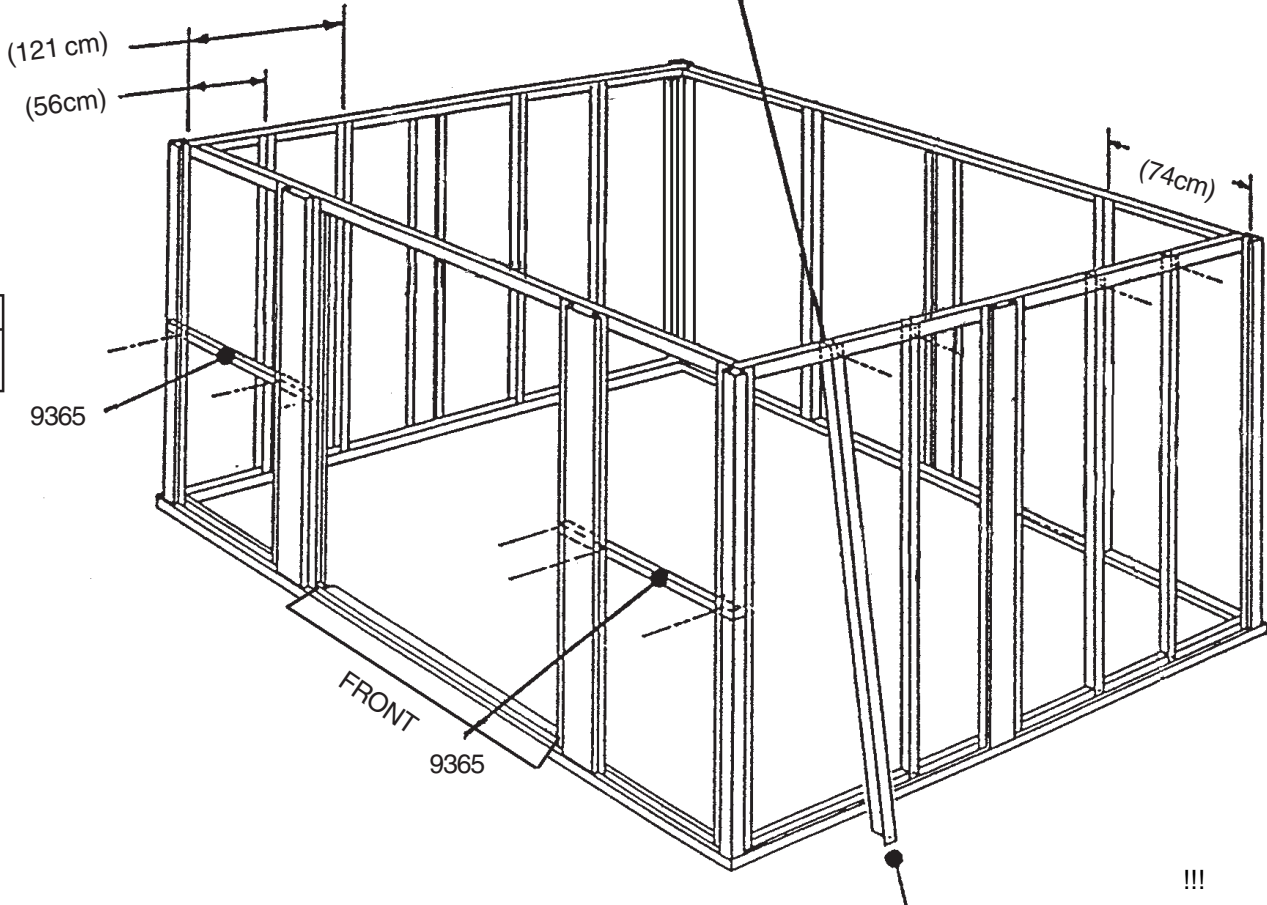

STEP
3

STEP
2

!!!

SX23

1

(STEP 1).

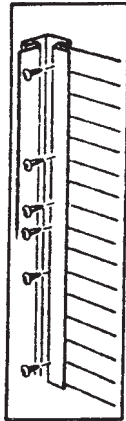

STEP 4

2

3

4

5

1-4

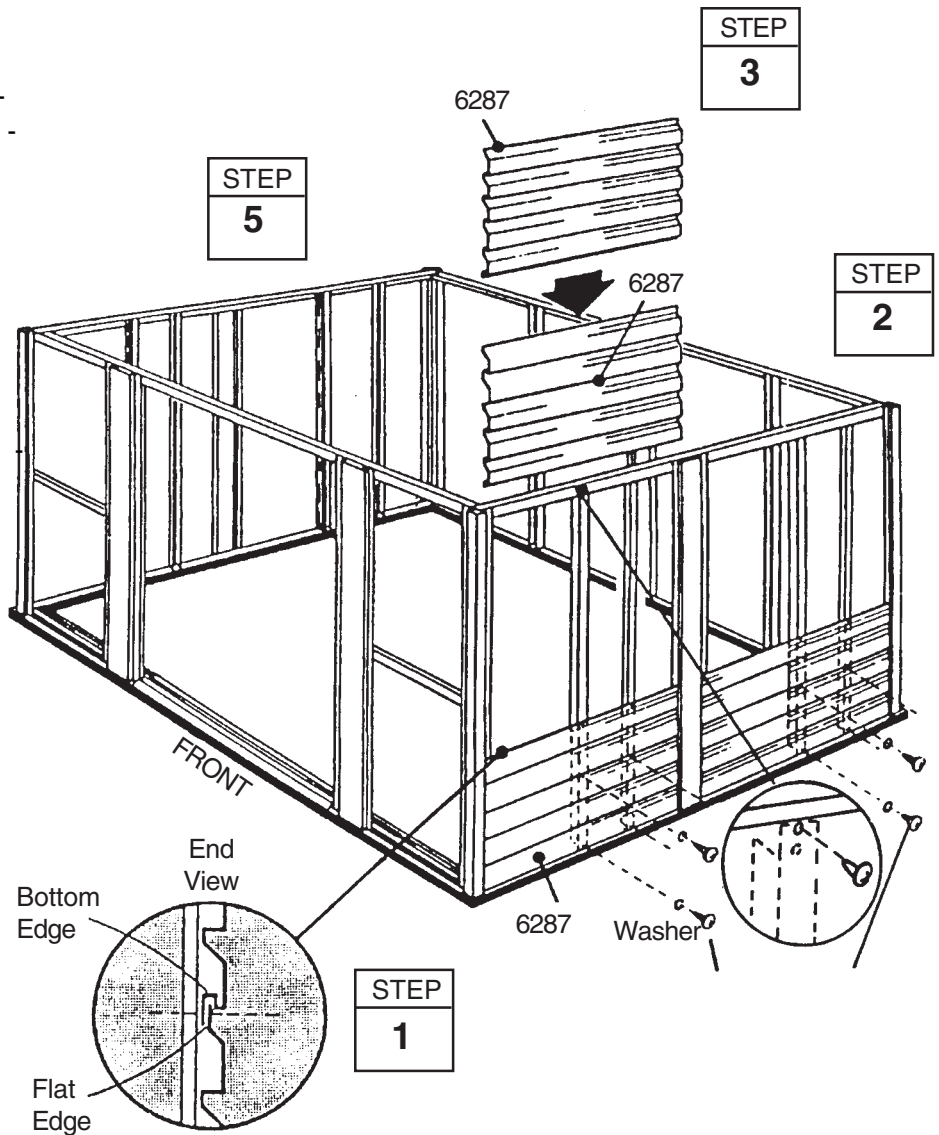

1

STEP
1

STEP
2

Fasten Top Center of Last Siding to Stud

2

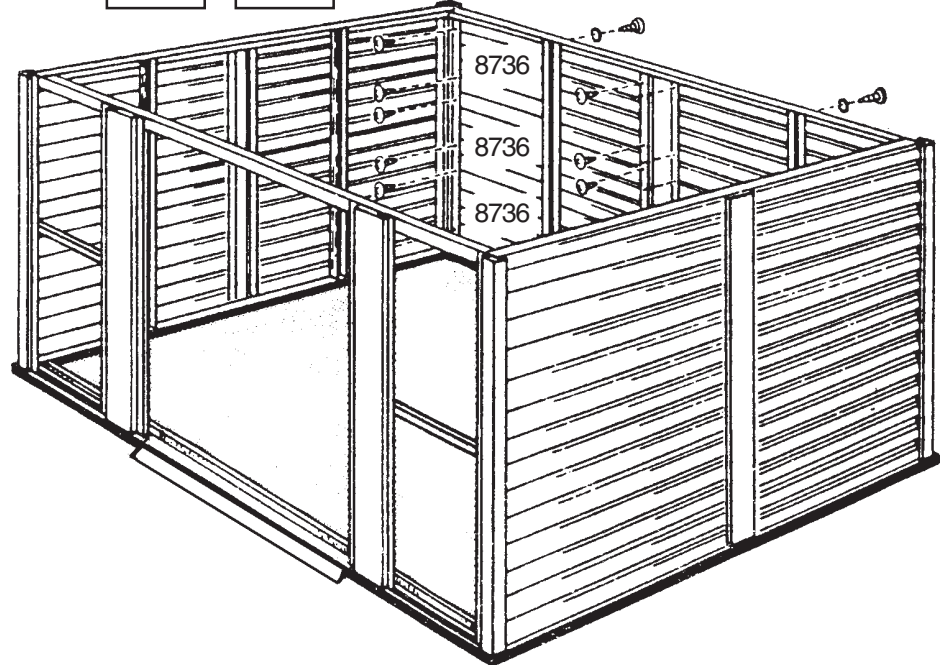

3

4

STEP
3

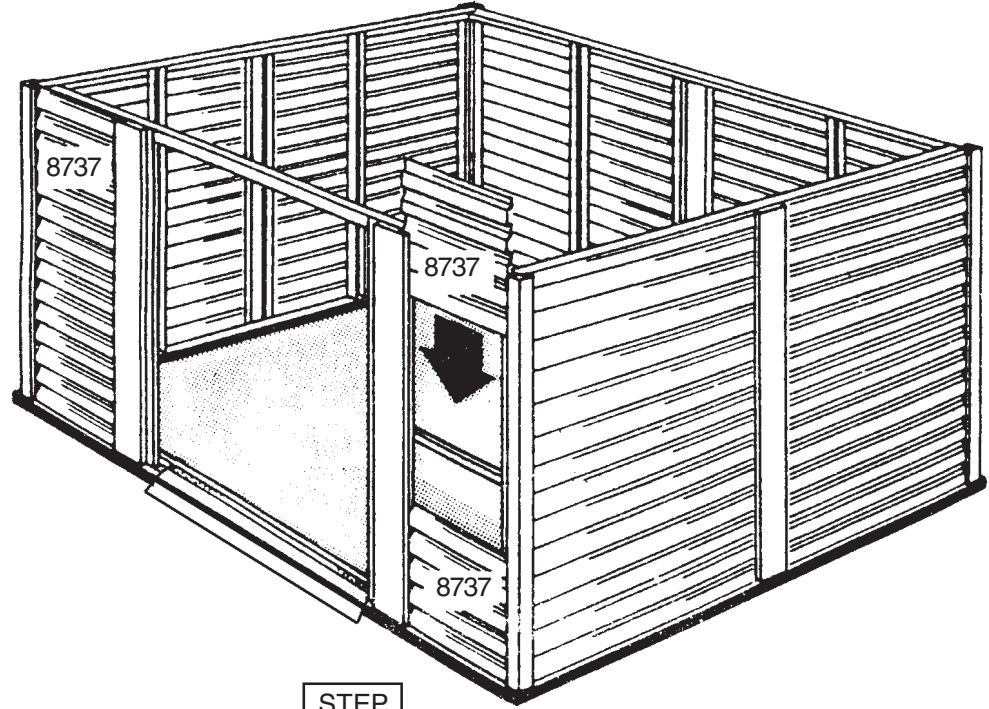

STEP
4

13

- 6000 Right Gable (2)
- 6001 Left Gable (2)
- 5971 Roof Beam Bracket (4)



1

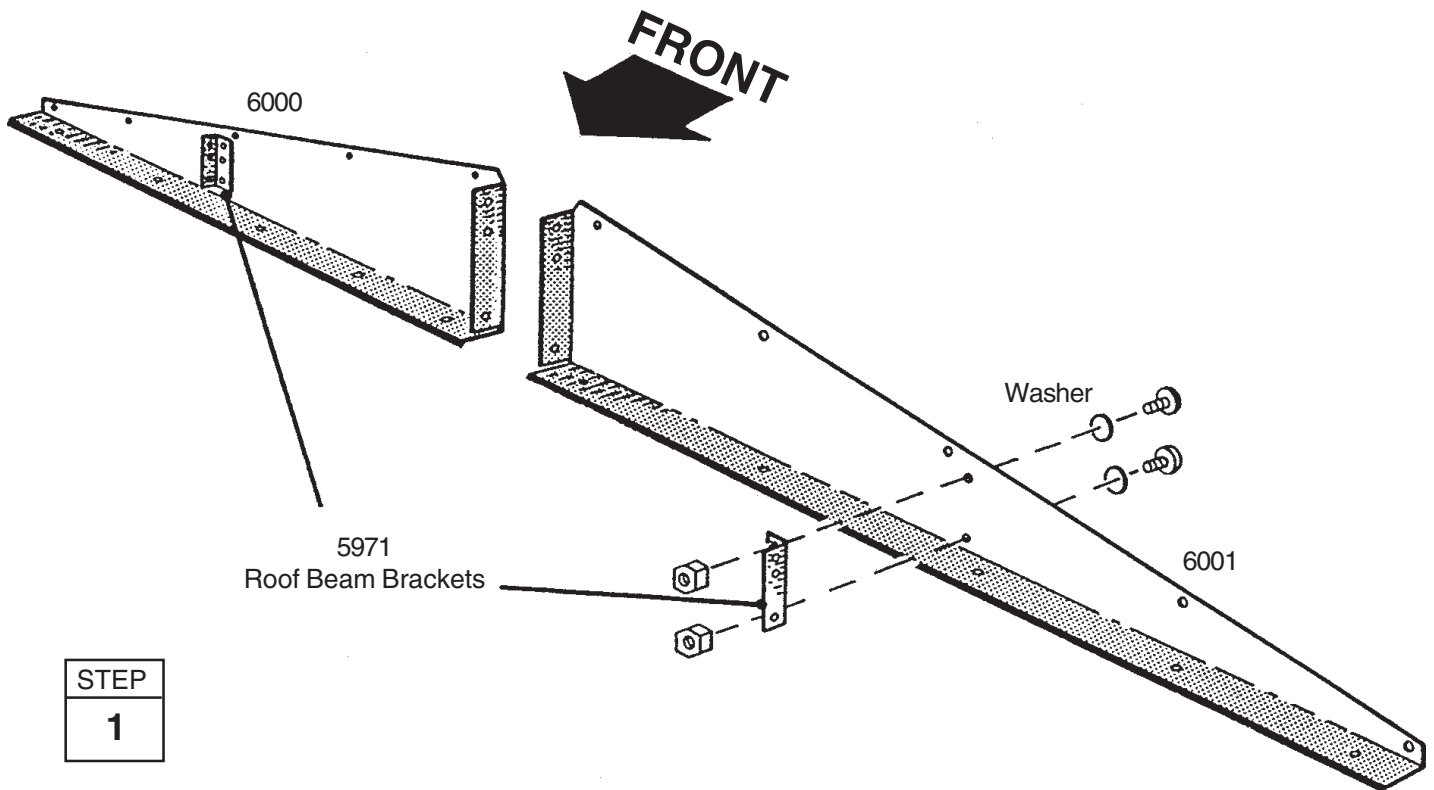
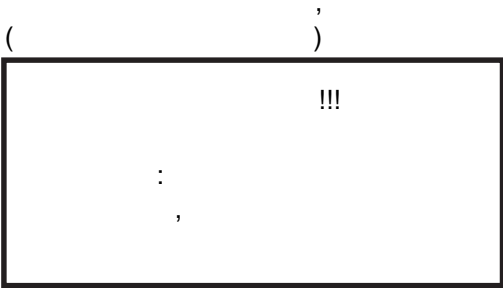

STEP
1

- Left Gable Assemblies (2)
- Right Gable Assemblies (2)
- 6635 Gable Brace (2)

1

2

3



6635

1 2

STEP
1

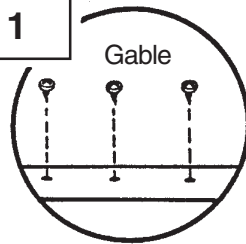

STEP
2

6635 Gable Brace

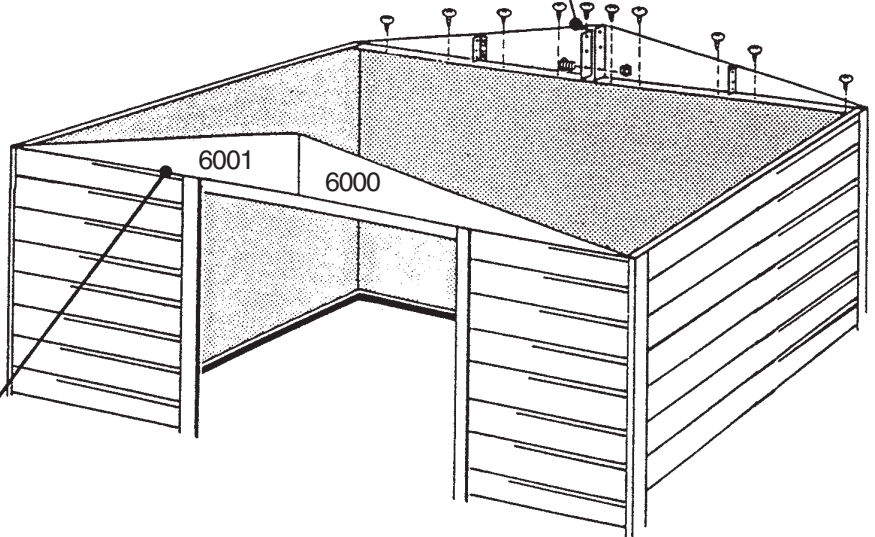

Track Supports 6228

STEP
3

1

2

3

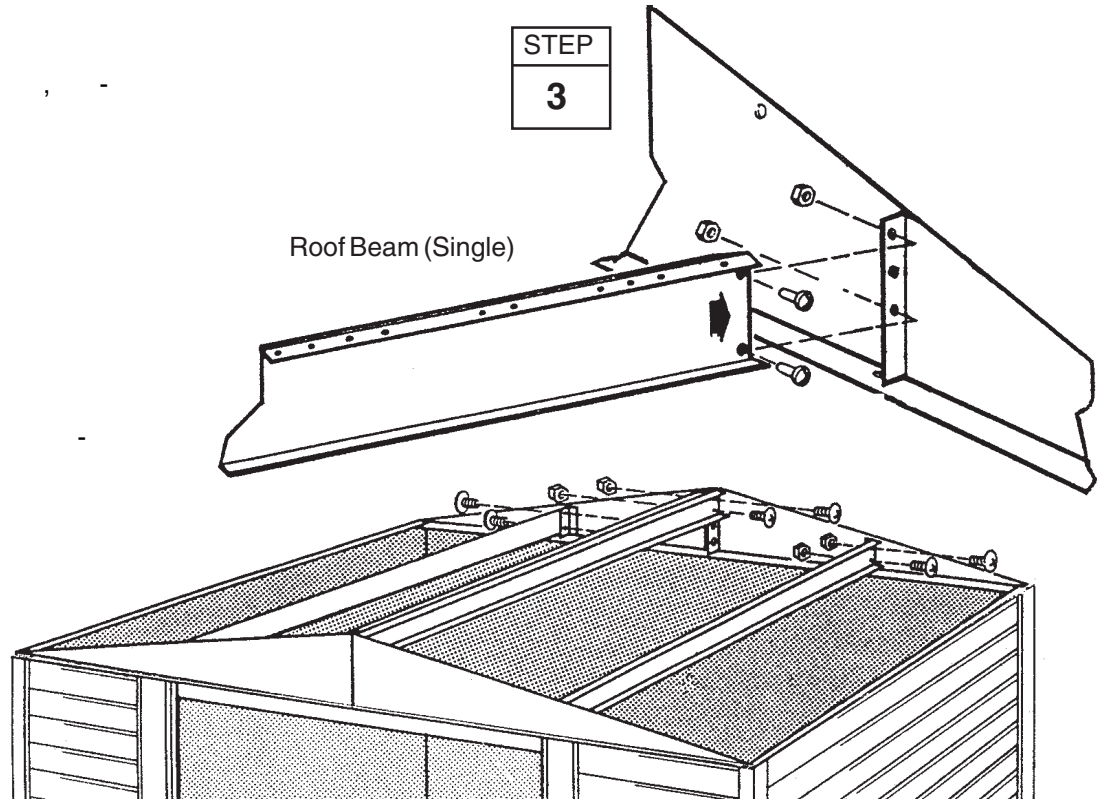

STEP 1

STEP 2

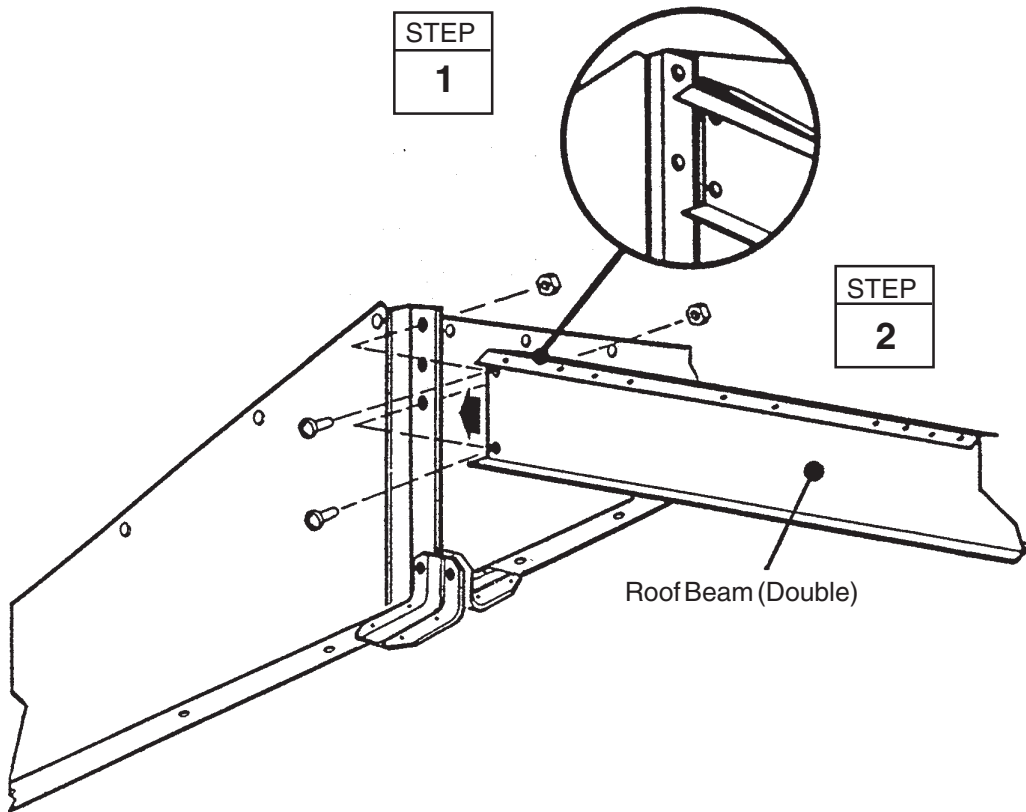

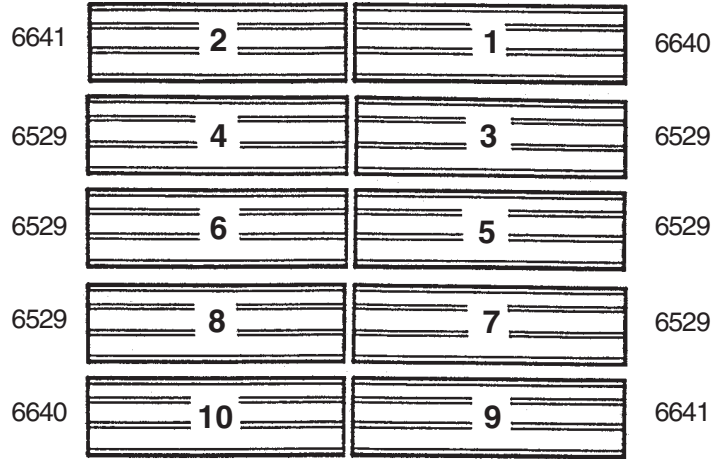

Front

STEP
1

1

STEP
2

2

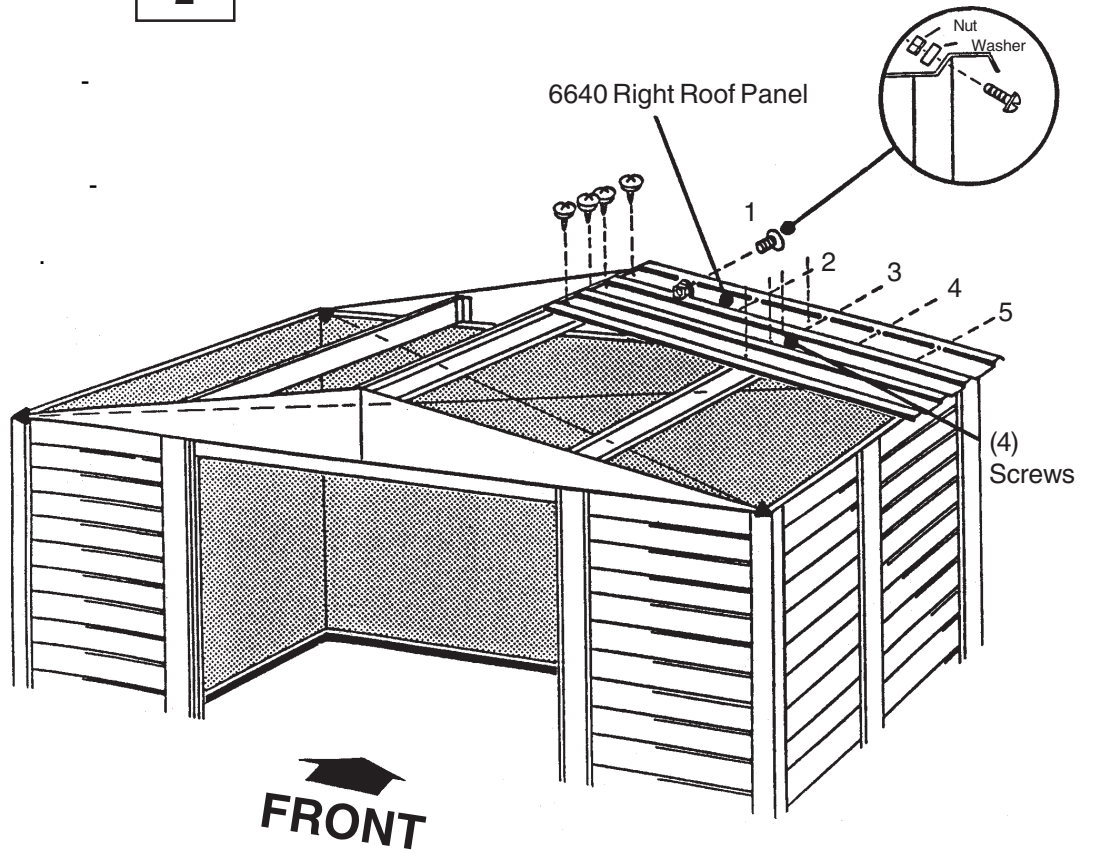

- 6641 Left Roof Panel (1)
- 6529 Roof Panel (2)
- 6869 Ridge Cap (1)

1

6641

2

3

6529

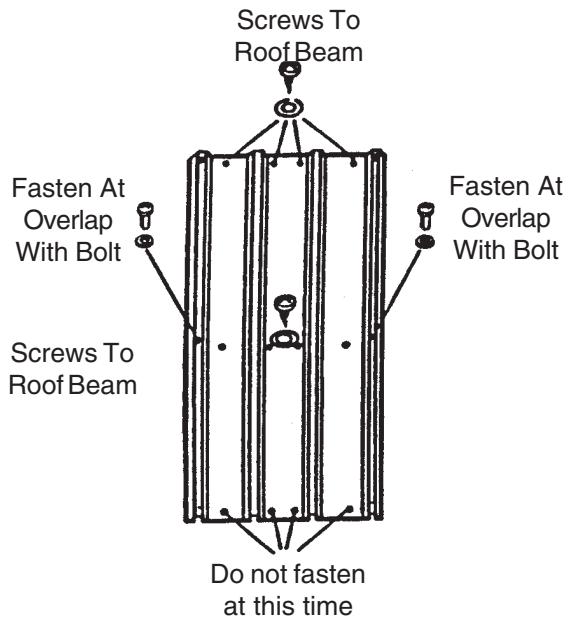

4

5

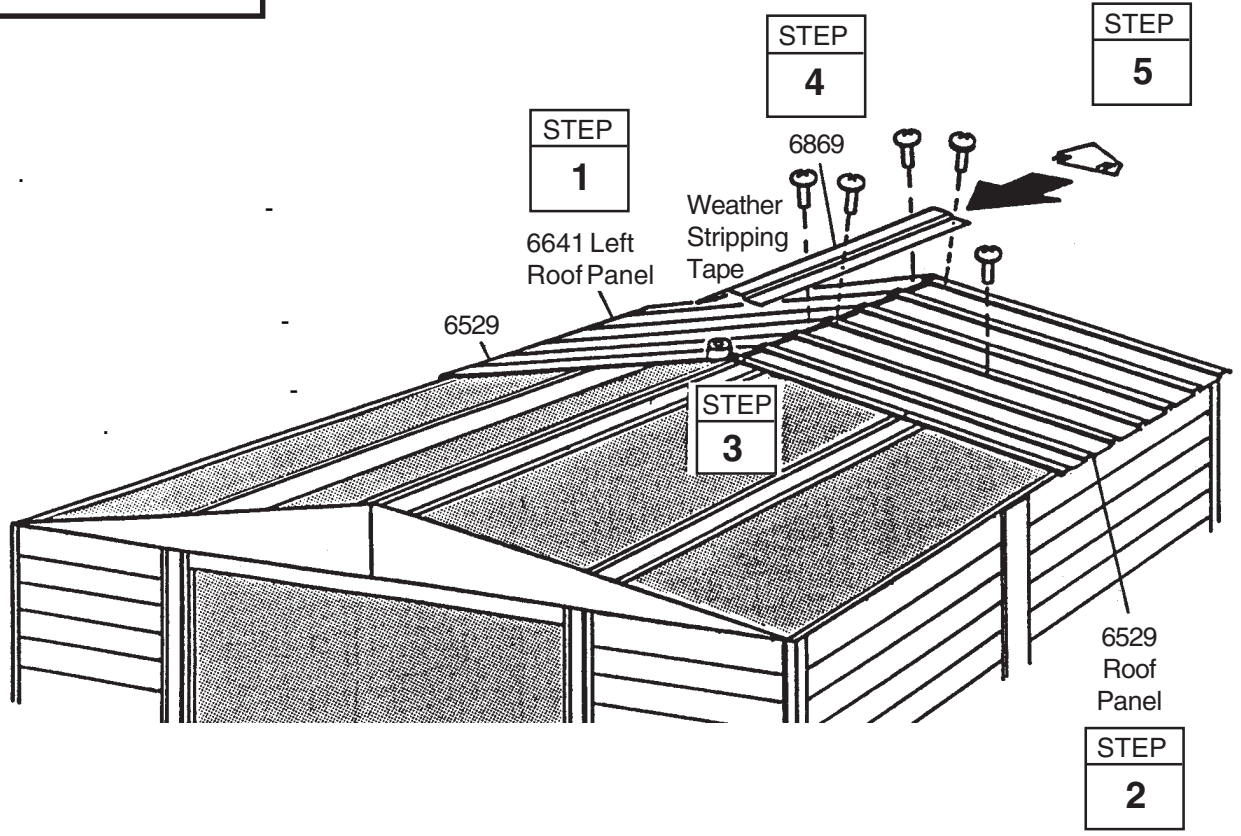

- 6868 Ridge Cap (1)
- 6529 Roof Panel (4)
- 6869 Ridge Cap (1)
- 6641 Left Roof Panel (1)
- 6640 Right Roof Panel (1)

1

68686

6529.

STEP
1

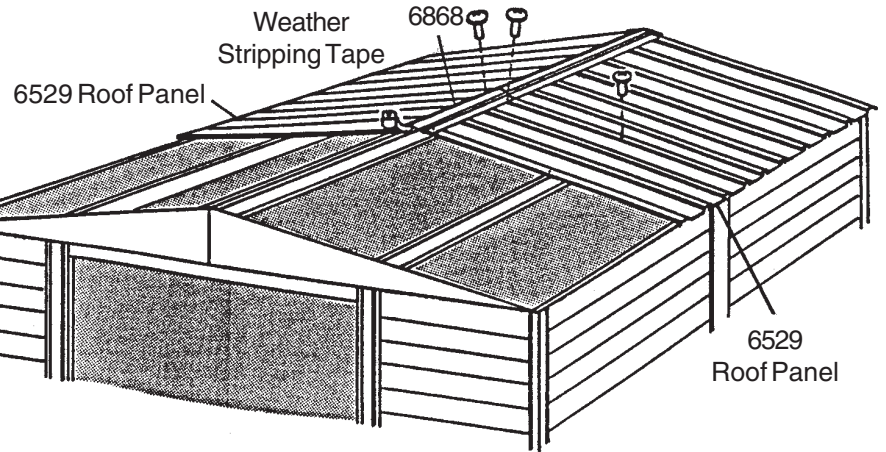

2

68686

6529.

3

6640,

6641

STEP
2

4

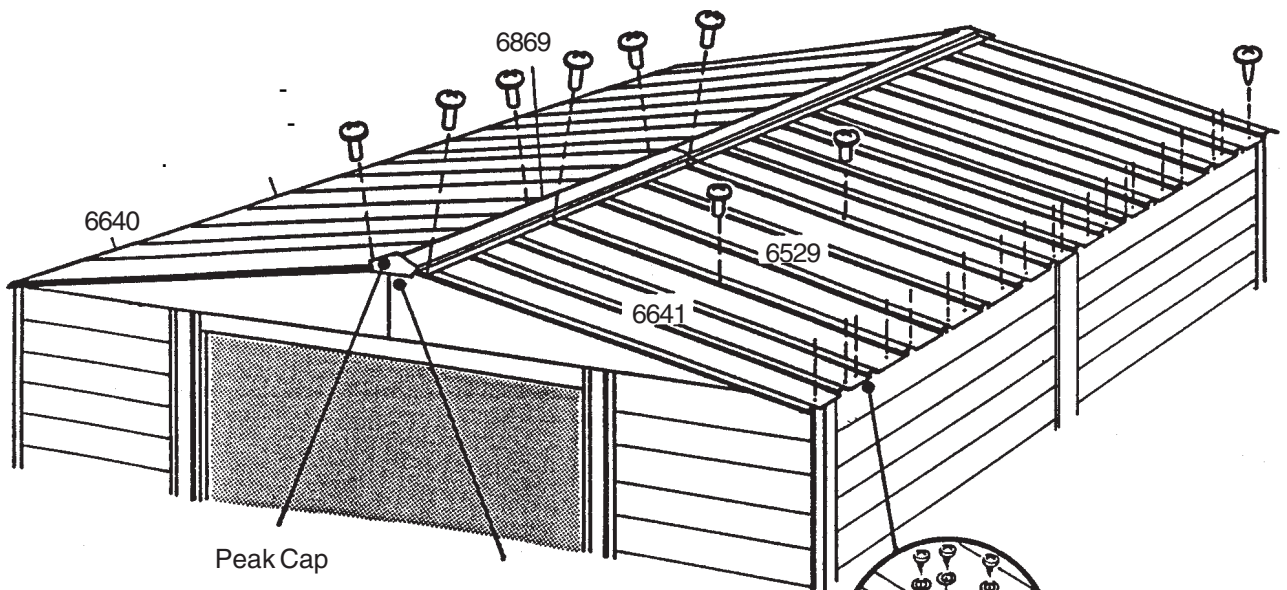

STEP
4

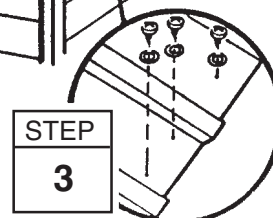

19

- 6015 Side Roof Trim (4)
- 6014 Side Roof Trim (2)

1



2

3

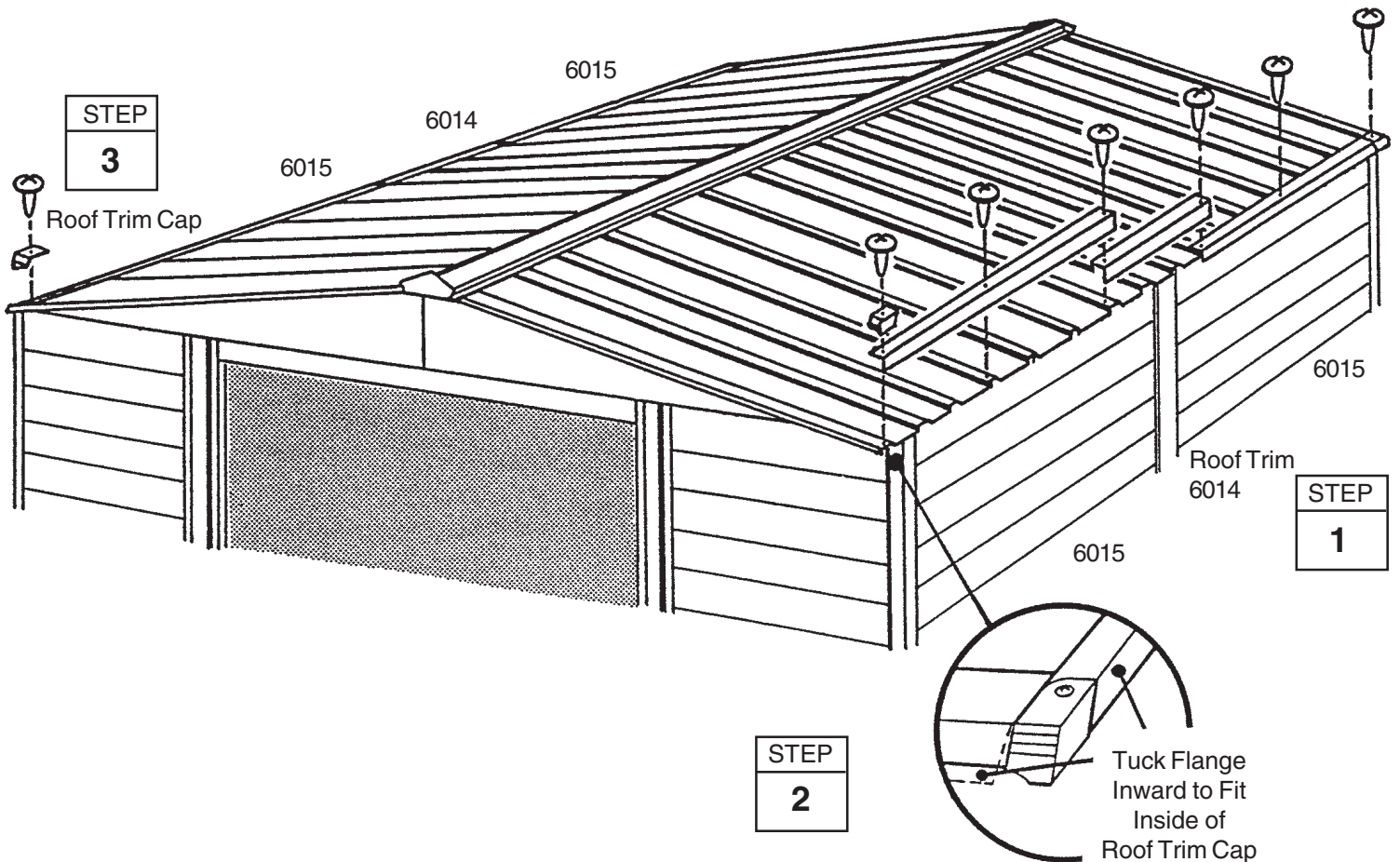

- 67731 Foam Board (2)
- 10493 Right and Left Doors (2)
- 10501 Horizontal Door Brace (4)
- 8641 Vertical Door Brace (2)

1
2
3
4
5
6
7

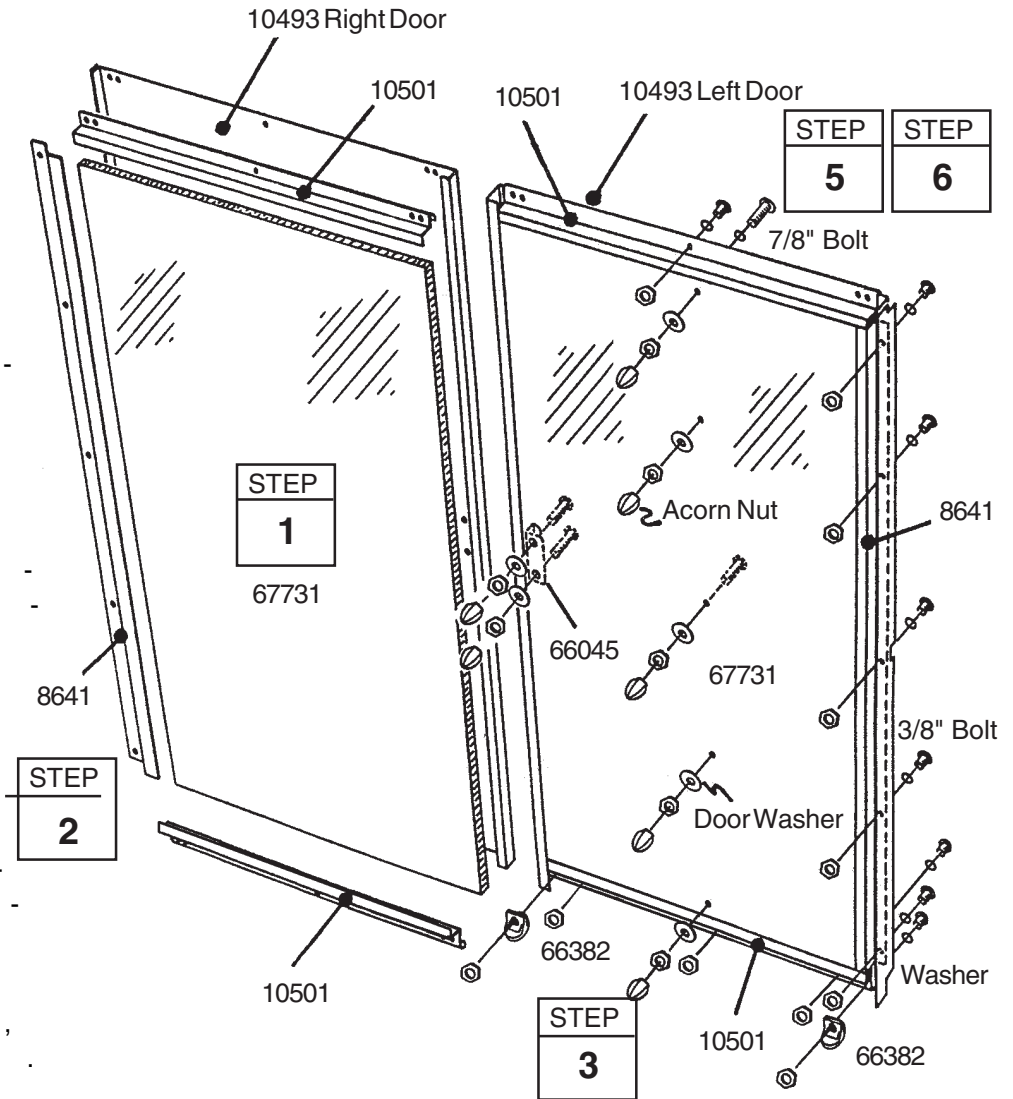

END VIEW
SHOWING:

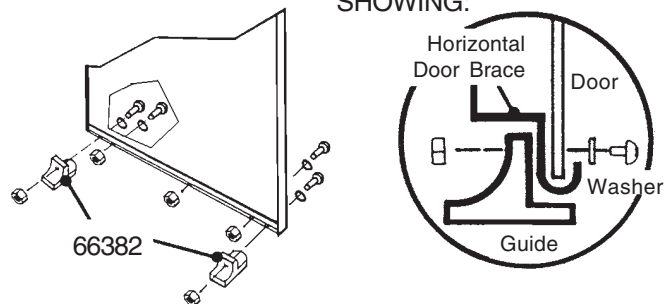

STEP
4

1 6

1

2

3

4

1-4

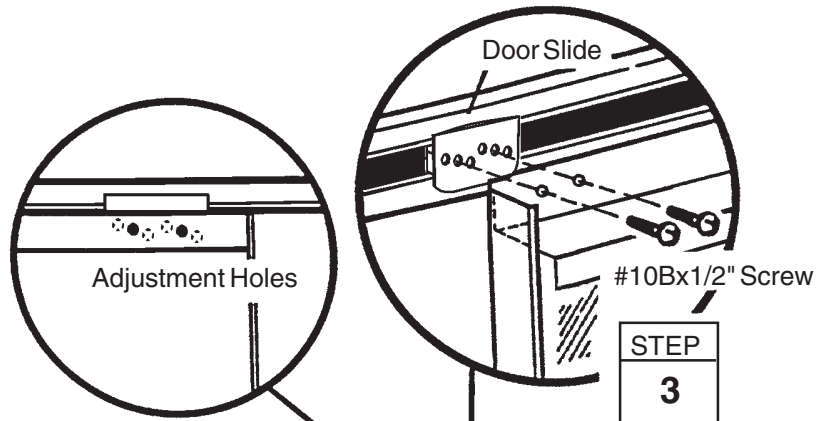
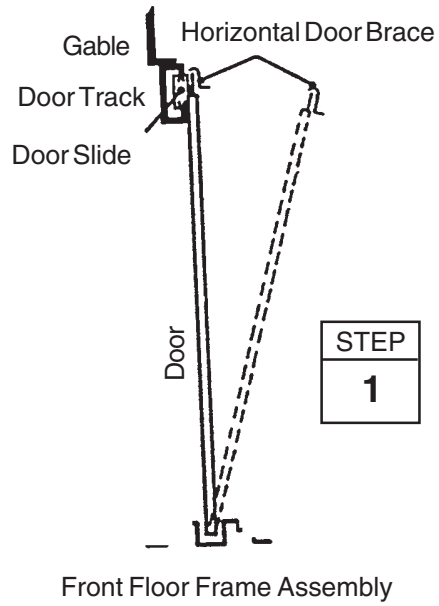

Adjustment Holes Allow Doors to Meet Evenly Along Their Length

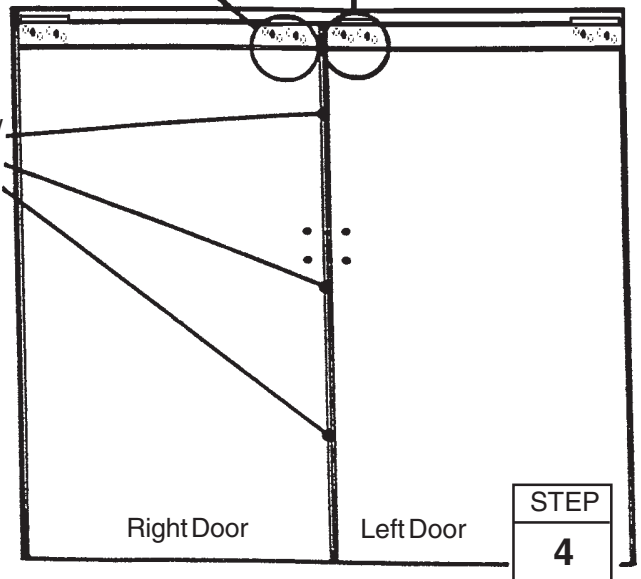

	1.	
-	,	.
,	2.	-
,	-	
(3.	-
.	-	.
-		-
,	-	,
,		-
.	4.	,
,		.
-	,	,
	.	-
	..	-